

# NEWS 2021

1971 - 2021  
**50**  
Years

50 year anniversary of HILLER!



HILLER wins the  
German Design Award!



HILLER trainees at  
excursion!

50 years anniversary HILLER GmbH

S. 8

HILLER wins the German Design Award

S. 11

HILLER trainees at excursion

S. 5



# THE WASTEWATER ASSOCIATION SAALE RELIES ON TECHNOLOGY FROM HILLER

The Saale wastewater association operates the wastewater treatment plant in Hof for 14 municipalities with a capacity of 290,000 inhabitants and remains the main operator in the area.

Since 2006 two HILLER thickening centrifuges have been providing the mechanical surplus sludge thickening at the sewage treatment plant and we are very pleased that the good cooperation with the wastewater association Saale will now continue with the installation of a HILLER high-performance centrifuge type DP664 for heavy-duty dewatering.

The plant will initially be designed as a containerised plant and, after completion of the necessary construction work, will be moved into the designated building together with an additional dewatering centrifuge.

The basis for assigning the order to HILLER was a large-scale technical performance comparison with our competition during the tendering phase.



## OVERVIEW

**projects . product applications . news . company news . service . sales partners . fairs**

Page:

- 2 ■ Waste water association Saale relies on technology from [HILLER](#)
- 3 ■ The new MA4 - mobile test and rental unit
- 4 ■ Successful cooperation with the WWTP Grazerfeld sustainably secured
- 5 ■ Technology and team building: two important blocks at the start of the new training year at [HILLER](#) GmbH
- 6 ■ Record year at [HILLER](#) GmbH
- 7 ■ Sewage Treatment Plant Klagenfurt installs [HILLER](#) system for centrate monitoring
- 7 ■ [HILLER](#) receives order from Novozymes A/S for 5x DP574 decanters

Page:

- 8+9 ■ 50 year anniversary of [HILLER](#) GmbH
- 10 ■ MSE [HILLER](#) receives order from Birdseye for 4x DP664 decanters
- 11 ■ [HILLER](#) GmbH wins the German Design Award
- 12+13 ■ Designing for greater efficiency: optimisations in the production & technology area ensure greater value creation
- 14 ■ Groundbreaking Ceremony at the WWTP Petershausen
- [HILLER](#) GmbH donates to Children's Cancer Aid Dingolfing-Landau-Landshut
- 15 ■ Employees of the [HILLER](#) GmbH donate for house fire in Bodenkirchen

# THE NEW MA4 MOBILE TEST AND RENTAL UNIT

In July 2020 we were able to add a very special mobile test and rental unit to our existing fleet.

The new MA4 is the first HILLER mobile unit with a DP664 decanter centrifuge and therefore perfectly suited for trials or rentals at larger sites with high throughput capacity requirements.

The new MA4 is also very special, because it is the first mobile plant which was completely designed and built within the Ferrum Group.

From design and project management to installation and pre-commissioning, everything was handled by HILLER GmbH, Spomasz Wronki Sp. Z o.o. and Ferrum AG.

The heart of the plant, the DP664 decanter, naturally comes from the Bavarian production halls of HILLER GmbH

The technical data of the new MA4 mobile unit:

- Turnkey mobile test unit on a mobile trailer
- DP664/FD in 40" container
- Decanter control system: HILLER SEE Control
- Control system of the entire plant: Siemens S7 1200
- Total weight including trailer: 30 tons
- Sludge throughput rate: up to 75m<sup>3</sup>/h
- Fully automatic polymer station with a input rate of up to 12,000l/h and up to 0.5% active substance with exclusive liquid polymer addition
- Integrated macerator for to protection of the plant periphery
- Automatic freight and polymer adjustment through integrated solids measurement
- HILLER CentrateControl for the maximum degree of dewatering by the CentrateControl HCC camera
- Easy control and operation for the customer
- After commissioning by a HILLER test or service technician the plant runs fully automatically and can be operated by the customer



# SUCCESSFUL COOPERATION WITH THE WWTP GRAZERFELD SUSTAINABLY SECURED

Since 2004 two powerful HILLER centrifuges for dewatering of the resulting digested sludge have been in operation for the waste water association Grazerfeld at the Wildon wwtp; a wastewater treatment plant with a capacity of 120,000 inhabitants in Southern Styria (Austria).

The invitation to tender for the renewal of the sludge dewatering plant, which was issued in spring 2020, based in its evaluation criteria for determining the best bidder on an economic long-term consideration of operating costs. This approach is being used more and more frequently due to the rapidly increasing disposal costs for the dewatered sewage sludge and supports the strategic orientation of our technology.

Once again, it was the economic facts that were decisive for the continuation of our highly appreciated cooperation with a well-known technology-oriented association.

HILLER GmbH were awarded the contract and installed two new DP574 decanters from the DecaBest series.



# TECHNOLOGY AND TEAM BUILDING: TWO IMPORTANT BLOCKS FOR THE NEW TRAINEES

On 1st September 2020, HILLER GmbH was pleased to welcome three new trainees. Ms. Martina Maier as industrial clerk, Mr. Lukas Gruber and Mr. Lukas Tarnowski as industrial mechanics.

To start the new training year, an exciting and varied trainee excursion was organised for all HILLER GmbH trainees with all trainers. It was particularly exciting for the three new trainees, as the day allowed them not only to experience the technology of HILLER high-performance centrifuges in action at a customer's site, but also to get to know all the other trainees and their trainers in a different setting.

To get a little insight into the day and to find out what the trip was like, especially for our newest apprentices, we asked our 1st year industrial clerk, Ms. Martina Maier, a few questions:

**Martina, what was the first thing that went through your mind when you found out that you were going on an excursion on the second day of your apprenticeship?**

I was actually very relaxed and just let the day unfold.

**Did the outing help you to get to know the trainers and the other trainees better?**

Yes, the trip definitely helped to get to know the trainers and the other trainees better, as you spent the whole day together it also helped to build a team.



**What did you do on the day?**

First we went by bus to Garching. There we got a guided tour of the sewage treatment plant. Around noon, we drove to Lake Chiemsee and were divided into three teams of five trainees each. Each team had to build a raft, which we then raced on Lake Chiemsee. In the evening, we all had a barbecue together.

**What do you remember about the sewage treatment plant? / What was special about the sewage treatment plant?**

The most spectacular thing about the sewage treatment plant was, of course, the HILLER decanter. We were able to see it in action and learn exactly how a decanter centrifuge works.

**What is your feedback on the day?**

I think the day was very successful. It was a lot of fun and we got to know each other better. You feel like a team right away now.

**Thank you Martina - the annual trainee excursion will definitely be continued!**



# RECORD YEAR AT HILLER GMBH

**In the challenging year 2020, HILLER GmbH was able to achieve a record result.**

Due to the good result of 2019, the management of HILLER GmbH had again set its goals high for 2020 and aimed for a record result. This goal was achieved despite the occurrence of the Corona pandemic. Turnover was increased by 12% compared to the previous year, with increased profitability at the same time.

**HILLER GmbH can thus be pleased about the best result in the company's 50-year history.**

This performance could only be achieved through the dedication of every single employee. We were therefore very pleased to be able to pay out a profit-sharing bonus to all employees, as we have done in recent years. Furthermore, wages and salaries could be increased as of April 2021.

## **Annual outlook 2021**

HILLER GmbH celebrates its 50th anniversary in 2021 and has again set itself high goals for this year. A very comfortable order book will be brought into the new year, which makes the management very optimistic for 2021.

Various developments are planned at the Vilsbiburg site, with €1.6 million being invested primarily in processes and facilities.

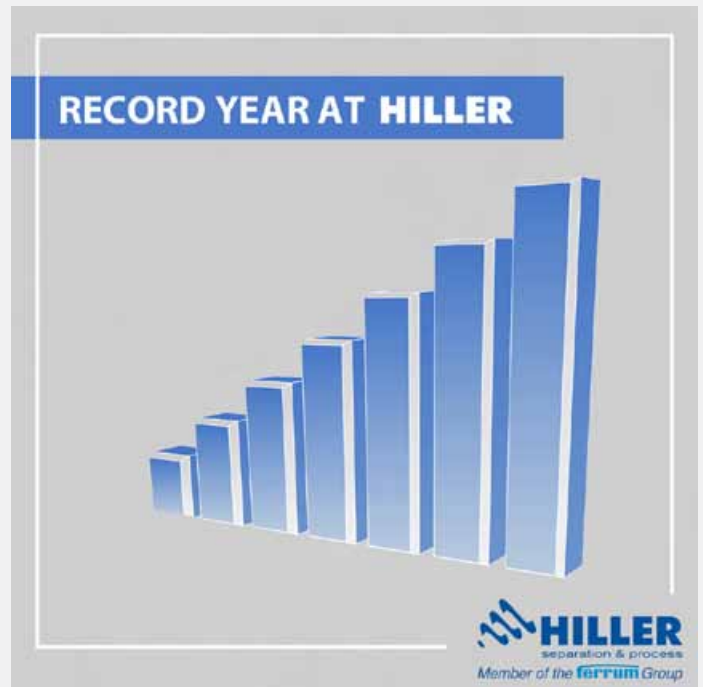

# WWTP KLAGENFURT INSTALLS HILLER SYSTEM FOR CENTRATE MONITORING AFTER LONG-TERM TEST

In 2019, the city of Klagenfurt (Austria) renewed the centrifuges installed at its sewage treatment plant (with 300,000 inhabitants). The decision was made in favour of HILLER's offer of two high-performance centrifuges type DP574.

The technology installed at the sewage treatment plant for biological waste water treatment places high demands on the centrate quality. To ensure the defined quality specification for the centrifuge centrate, the HILLER HCC CentrateControl system was

installed on one of the two dewatering lines and tested in practical operation for six months.

After this the HILLER CentrateControl system was retrofitted to the second dewatering line and its function was once again confirmed in practical operation.

**Further information about the HILLER CentrateControl can be found at: <http://hillerzentri.de>**

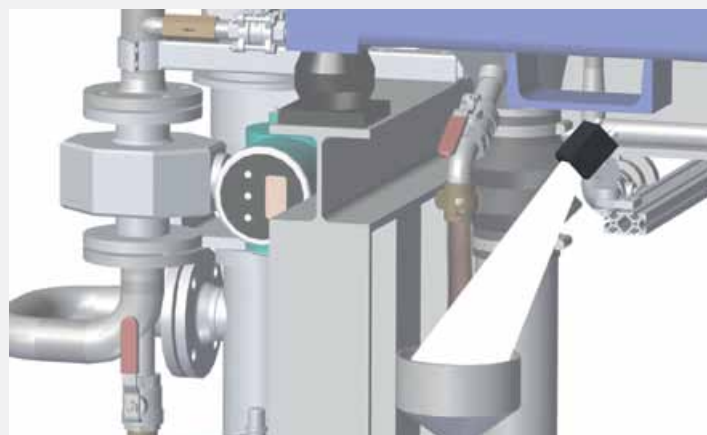

# HILLER GMBH RECEIVES ORDER FROM NOVOZYMES A/S FOR 5x DP574 DECANTERS

For the Novozymes site in Kalundborg Denmark HILLER will supply 5 pieces HILLER DecaPress DP574 decanters as replacement of the existing decanters.

The decanters are being used for the dewatering of the biomass from the Novozymes production plant. The choice for HILLER was made after on-site testing.

We are pleased about the further cooperation with our customer!

For more information please contact:

Mr. Gert Snijders  
MAIL: [gert.snijders@hillerzentri.de](mailto:gert.snijders@hillerzentri.de)  
MOBILE: +31-318 731 400



# 50 YEAR ANNIVERSARY OF HILLER GMBH

**In 2021 HILLER GmbH is celebrating its 50th anniversary and can look back at five decades of experience in the development and manufacture of decanter centrifuges and plants for solid-liquid separation.**

**50 years is half a century of HILLER standing for:**

- highest quality
- absolute reliability
- continual evolution
- team HILLER

## **50 years highest quality**

Because of our, now more than 50 years experience in the development and manufacture of decanter centrifuges for solid-liquid separation, we can guarantee our customers the highest product quality, automation and process stability.



For Georg Hiller senior, the company founder, quality had the highest priority from day one. In order to constantly meet this high standard, we focused on the highest standards and continuous quality control, not only in production in our plant in Vilsbiburg, but also through the choice of our global supply network.

At our production site in Bavaria we are known by our national and international customers for the high quality products and services fitting for the title of ‚Made in Germany‘.

Furthermore, continuous internal process optimisation and external certification has contributed to maintaining and expanding our high standards.

## **50 years of absolute reliability**

Reliability: this word describes not only our products and services, but also our customer service.

Our decanters have always been distinguished by high reliability. Thanks to their long life and high durability, in conjunction with perfected maintenance concepts, our customers find their decision to buy HILLER decanters is always a long term, attractive solution.

And should it be urgent to work on any components related to our machines and plants, in this regard HILLER has always scored with a quick overhaul using the latest machine developments.

Our customer service is one further pillar for the high customer satisfaction. Even before purchasing, our interested customers are extensively consulted and solutions for their problems are conceived. Thanks to the availability of HILLER test and rental equipment, customers and those interested can test the performance of the equipment on site, or rent it, even for a longer period of time. When purchasing a new machine or plant, the HILLER project team will, when requested, take over the complete engineering, from plant extension and automation technology, to site supervision and acceptance of the turnkey decanter plant.

HILLER is an experienced partner for every aspect of the project, from installation planning, project planning of all the necessary individual electrical engineering components, to the overall planning of process-oriented customer solutions.

In this way we guarantee for our customers a dependable and economic operation of their plant, with a complete solution from one source.



# A REASON TO CELEBRATE

To meet the requirements of process stability, in combination with greater operation security and plant useability, HILLER launched a highly effective servicing concept very early on. Our highly flexible customer service takes care of the systems installed, through the commissioning, maintenance servicing, training, process optimisation and machine diagnostics on site and online. These are tried and tested building blocks for the safe and economic operation of our customers' installations.

## 50 years continual evolution

In these fast moving times, standing still is stepping backwards. As an innovative company we never rest, but instead are constantly researching and developing further in order to improve our products, implement new applications and continually make our processes more effective.

An example is the patented HILLER Centrate Control. In order to ensure a consistently high degree of separation, the centrate from the machine is constantly monitored with the aid of an object sensor. In addition to the warning when there are poor centrate values, polymer consumption can also be optimised and unnecessary overdosing avoided. This results in cost savings for our customers through automated regulation and an improvement in the separation result.

The HILLER Remote Monitoring is a further recent innovation. With the help of a modem and data line, any disruptions at the customers' plants can be detected, assessed and rectified within minutes by HILLER service personnel.

This possibility of remote monitoring has proved to be very important for us and our customers, especially during the Corona pandemic.

Our leadership in control technology was further expanded with the new version of the HILLER SEE-Control *pro*. Its visualisation sets new standards in the servicing of decanters and wins one over with a fresh and simple design. The alarm and trend analysis supports the user and ensures a best possible machine performance. Additionally, our completely newly revised visualisation received the German Design Award 2021 as winner in the category *'Excellent Product Design- Human-Machine-Interface'*.

## 50 years Team HILLER

After 50 years, HILLER GmbH can look back on a long, eventful history having experienced both highs and lows with its staff. That has made HILLER what it is today.

Without our loyal customers, longstanding business partners and many highly engaged staff who have helped over these 50 years, along with the company founder Georg Hiller senior, to build up and further develop the company, the current success would never have been possible.

The large number of highly qualified and skilled workers in every department is the foundation of the company.

In the meantime, about 180 employees belong to Team HILLER, of which about 150 are based at the Vilsbiburg site.



# MSE HILLER RECEIVES ORDER FROM BIRDSEYE FOR 4x DP664 DECANTERS

## Background

Frozen peas have been produced in the UK since 1946 after the fast freezing process was developed in 1929 by Clarence Birdseye.

Birdseye are one of the largest pea processors in the world, and the largest in the UK, processing and freezing around 50,000t of peas per year during the harvest season from June to August.

Their facility at Hull is situated in the centre of a 30-mile radius of 200 growers, allowing the peas to be picked, transported and frozen in the shortest possible timescale.



During the pea season, the factory processes 1,000t of peas 24-hours a day.

Associated with this is the water which is used to wash the peas and as fresh water needs to be used the wastewater was traditionally treated by the local water company.

With tightening of legislation and permit standards, Birdseye asked MSE HILLER, to develop a proposal to treat 400m<sup>3</sup>/h of their water leaving site.

In June 2019 MSE HILLER carried out pilot testing during the pea season to prove the concept of treatment by centrifugation.

This proved successful and the company was invited to develop a full scale process with 4 pieces of DP664 HILLER decanters and associated plant construction.



The space constraints on site and the short project timescale was going to be a challenge, but a proactive project team was assembled, including the client and site operator, to ensure a timely delivery of the project in readiness for the 2020 season.

With only a few days to spare before the pea season began, MSE HILLER delivered the completed plant on time and on budget, despite the challenges of building a large process plant during the Covid-19 outbreak.

Ivan Fomin, Managing Director at MSE HILLER explains, "The client trusted us to deliver this solution and worked positively and proactively to help us achieve the target. It is great to see what solid teamwork can achieve under challenging circumstances".



# HILLER GMBH WINS THE GERMAN DESIGN AWARD

## About the German Design Award

The German Design Award is one of the most renowned design awards worldwide and enjoys a high reputation far beyond specialist circles. The German Design Award discovers and presents unique design trends. Every year, innovative products, their manufacturers and designers are honoured. Whoever wins against the top-class competition has successfully proven to be one of the best.



**This year Hiller GmbH is the winner in the category *Excellent Product Design – Human Machine-Interface*.**

The award is for the visualization of the new HILLER SEE-Control *pro* unit, which will replace the current decanter control unit in 2021. It sets new standards in the operation of decaners and impresses with its fresh and simple design.

The screens are clearly arranged and the menu navigation is clearly structured. Thus, the display can be operated intuitively by any user. Alarm and trend evaluations support the operator and ensure the best possible decanter performance.



Smooth colour transitions and clear fonts provide the visual appeal of the display. In addition, a light/dark switching function has been integrated for optimum operability under changing light conditions.

**HILLER GmbH is very pleased to have won the German Design Award 2021!**



**GERMAN  
DESIGN  
AWARD  
WINNER  
2021**

# DESIGNING PROCESSES FOR GREATER EFFICIENCY: OPTIMISATIONS IN THE PRODUCTION

**HILLER GmbH has been developing and manufacturing state-of-the-art decanting centrifuges and solid/liquid separation systems at its Vilsbiburg site for over 50 years.**

**As a mechanical engineering firm, technology has always been at the heart of the company.**

**Continuously improving and optimising production processes and workflows is standard practice at HILLER.**

For example, multiple optimisations and improvements were implemented last year to improve value creation, shorten lead times and consistently structure all work steps for increasing quality.

## **Introduction to Shopfloor Management (SFM)**

„Shop floor“ refers to the „factory hall“, i.e. the place where value is created. The aim of the Shopfloor Management method is to implement measures for continuous process improvement together with all process participants at the place of value creation and without long decision paths.

This results in the following benefits for HILLER GmbH:

- more flexible response to deviations
- sustainable problem-solving
- proactive action
- improved communication and greater transparency between employees and managers

Shop floor management was successfully implemented in 2020 together with all parties involved in the COO, assembly, work preparation, programming, warehouse, welding, machining and development/design departments.

## **Introduction of 5S – Clarity and workplace organisation**

The 5S method is another approach in the field of lean management. The aim of the 5S method is to organise your own workplace appropriately to avoid wastage of all kinds, such as time spent searching for items.

The 5S's stand for:

- sort
- set in order
- shine (to clean)
- standardise
- self-discipline

Before the introduction, the 5S multipliers in the individual departments were first trained to establish a common standard.



Thanks to the 5S method, employees from different departments can be deployed more flexibly, as the organisational structure is standardised in every workplace. Similarly, the training time for trainees and new employees during their assignments in the respective departments is also shortened.

Thanks to the commitment of employees to consistently repeat the 5S steps, the already high level is being optimised even further.

## **Layout optimisations in repair and other manufacturing areas**

To shorten work and transport routes and optimise work processes, individual areas within the production halls have been relocated or redesigned. The areas of dispatch and goods receipt have been physically separated from one another to remove the previous material flow node and to ensure more effective processing of the work steps without hindrances.

**Optimisation of repair procedures – reduction in turnaround time by 2 weeks**

# & TECHNOLOGY AREA ENSURE GREATER VALUE CREATION

In addition to our on-site customer service, we have also been servicing and repairing our decanters to meet the highest customer requirements in our production halls for decades.

The focus is on the shortest possible throughput time and at the same time the highest quality of maintenance services.

To meet these requirements and further improve our performance, a dedicated repair area has now been created where all work steps can be carried out in physical proximity. The previous repair warehouse has been enlarged, a modern washing container has been purchased and the dismantling cell and corresponding office relocated.



This has made it possible to separate the repair process from the new machines completely, resulting in huge savings on internal and external transport routes. This saw a reduction in the average lead time for a repair order by a whole 2 weeks.

## Process optimisations

Many internal processes were worked on in parallel, including in the warehouse area. Here, the packaging process was optimised across departments in the SAP system and supplemented by an additional end-of-line check.

Likewise, the small parts warehouse has been optimised with regard to easier findability and clarity.

## Increase in production capacity thanks to in-house manufacturing

HILLER decanters have always been characterised by a high proportion of in-house production and thus consistently highest quality from a single source. To further increase this share and at the same time increase production utilisation, investment was made in a new submerged arc welding system.



Using this system, roll-bent and submerged arc-welded components can be used as input material for our drum components as an alternative to centrifugal casting. The investment in the new system and the manufacturing processes significantly increase the flexibility and cost-effectiveness of rotor production for our decanters.

## Further optimisations planned

In the context of a continuous process, further improvements and optimisations are constantly being implemented and planned. Following the same strategy, further projects are also planned for this year.

# GROUNDBREAKING CEREMONY AT THE PETERSHAUSEN SEWAGE TREATMENT PLANT

The Petershausen municipality has been planning the construction of a new sewage sludge dewatering plant for quite some time.

On 16th April 2021, the groundbreaking ceremony took place at the Petershausen sewage treatment plant with the main companies involved in the project.

In addition to supplying the high-performance centrifuge, HILLER GmbH has been commissioned with the installation of the complete plant periphery of a ready-to-operate sludge dewatering plant. The basis for awarding the contract was an economic comparison with the screw press technology.

**We are looking forward to the future cooperation and wish much success in the delivery of the project!**



## HILLER GMBH DONATES TO CHILDREN'S CANCER AID DINGOLFING-LANDAU-LANDSHUT E.V.

Normally, HILLER sends a lot of Christmas cards to customers and business partners by mail at the end of the year. For the sake of the environment, this was abandoned from this year on and the company switched to electronic Christmas greetings.

Since this changeover also entails a considerable cost saving of € 1,700, HILLER wanted to donate the amount one-to-one for a good cause.

In the end, the decision was made in favor of the "Kinderkrebshilfe Dingolfing-Landau-Landshut e.V." which is a local Children's Cancer Aid Association that currently supports around 115 families with children suffering from cancer. Unfortunately, due to the Covid-19 restrictions, the donation could not be handed over to the association in person.

Therefore, Ms. Manuela Habermeier, sales assistant at HILLER and responsible for the annual Christmas card mailing and Ms. Tanja Girtzer, responsible for Marketing & PR at HILLER are on the picture as representatives. Ms. Ulrike Eckhart, 1st chairwoman of the association, expressed her sincere thanks by

telephone for the donation, which is very important especially this year, as the willingness to donate has generally decreased considerably. In addition, due to the restrictions caused by the Corona pandemic, no benefit events could be held.



# EMPLOYEES OF THE HILLER GMBH DONATE FOR HOUSE FIRE IN BODENKIRCHEN

The house fire in Bodenkirchen (A small town near Vilsbiburg, Bavaria) with several fatalities has deeply affected many people in the region. A wave of helpfulness began. In addition to sums of money, many materials were also donated to the family.

The employees of the HILLER GmbH also wanted to make a contribution. In a spontaneous action it was decided that each employee could convert a bonus from the employer on the occasion of the company holidays at Easter partially or completely into a voluntary donation.

In this way a total of € 4,680 was collected for this good cause.

In this way the staff of HILLER GmbH would like to send a sign of solidarity to the family who have been struck by an unbelievable stroke of fate.

The management of the HILLER GmbH took advantage of this strong signal of sympathy from its employees and rounded up the amount to a total of € 7,000.

In June 2020 the donation was handed over to the mayoress of Bodenkirchen, Ms. Maier and the treasurer, Mr. Dennerl, by the personnel officer Ms. Kristina Brauweiler on behalf of the staff.

On behalf of the family, the mayoress thanked the staff and the management of the HILLER company for the largest single donation received so far.



HILLER GmbH  
Schwalbenholzstraße 2  
84137 Vilsbiburg

Phone +49 8741 48-0

info@hillerzentri.de  
www.hillerzentri.de

## APPLICATIONS OF THE HILLER DECANTER TECHNOLOGY

Oil, Gas & Energy Industries



Chemistry-, Process- & Pharma Industries



Food- & Beverages



Environment & Wastewater



Mining, Tunneling & Drilling Fluids

